



**HAL**  
open science

## Application of holonic paradigm to hybrid processes : case of a water treatment process

Carlos Indriago, Olivier Cardin, Naly Rakoto, Edgar Chacon, Pierre Castagna

### ► To cite this version:

Carlos Indriago, Olivier Cardin, Naly Rakoto, Edgar Chacon, Pierre Castagna. Application of holonic paradigm to hybrid processes : case of a water treatment process. Service Orientation in Holonic and Multi Agent Manufacturing and Robotics, 594, pp.39-48, 2015, Studies in Computational Intelligence, 10.1007/978-3-319-15159-5\_4 . hal-01693164

**HAL Id: hal-01693164**

<https://hal-nantes-universite.archives-ouvertes.fr/hal-01693164>

Submitted on 27 Nov 2019

**HAL** is a multi-disciplinary open access archive for the deposit and dissemination of scientific research documents, whether they are published or not. The documents may come from teaching and research institutions in France or abroad, or from public or private research centers.

L'archive ouverte pluridisciplinaire **HAL**, est destinée au dépôt et à la diffusion de documents scientifiques de niveau recherche, publiés ou non, émanant des établissements d'enseignement et de recherche français ou étrangers, des laboratoires publics ou privés.

# Application of Holonic Paradigm to Hybrid Processes: Case of a Water Treatment Process

Carlos Indriago, Olivier Cardin, Naly Rakoto, Edgar Chacón  
and Pierre Castagna

**Abstract** The holonic paradigm has been widely studied in the context of manufacturing. These productions are discrete type because operations included do not involve continuous evolution variables. A different system class is studied here—hybrid system, which includes systems with piecewise continuous evolution and whose changes are related to the evolution of discrete variables. In this case, a reconfiguration of the system is usually necessary, and holonic paradigm is an appropriate response to the need for flexibility arising. This paper proposes an adaptation of holonic reference architecture on a hybrid system case. The proposed model is composed of the union of the hybrid model and the holonic model, where the proposed controller is represented by the product holon and the order holon, the interface is represented by the logical part of the resource holon, and finally the production system is represented by the physical part of the resource holon. A case study based on a water treatment process is investigated to demonstrate the applicability of PROSA based concepts to a hybrid system.

**Keywords** Holonic manufacturing systems · Hybrid systems · PROSA · Water treatment process

---

C. Indriago · O. Cardin (✉) · N. Rakoto · E. Chacón · P. Castagna  
LUNAM Université, IUT de Nantes—Université de Nantes, IRCCyN UMR CNRS 6597,  
Institut de Recherche en Communications et Cybernétique de Nantes, 2 avenue du Prof. Jean  
Rouxel, 44475 Carquefou, France  
e-mail: Olivier.Cardin@univ-nantes.fr

C. Indriago  
e-mail: Carlos.Indriago@univ-nantes.fr

N. Rakoto  
e-mail: Naly.Rakoto@mines-nantes.fr

E. Chacón  
e-mail: echacon@ula.ve

P. Castagna  
e-mail: Pierre.Castagna@univ-nantes.fr

# 1 Introduction

In production systems there are discrete processes, where the individual parts are produced using various discrete loosely coupled operations such as machining, drilling, grinding etc.; then these parts are placed together in an assembly line to create the main end-product. On the other side, there are continuous processes that involve continuous flow of materials (such as Bulk chemicals) and utilities through process units interconnected via piping streams. Between the discrete systems and continuous systems, there are systems called semi-continuous class of processes, which, similarly to continuous processes, also involve continuous flow of materials and utilities but are not operated with a purely steady-state mode. Semi-continuous processes are particularly important in this work, specifically systems called “dynamic hybrid systems”. According to Koutsoukos et al. [1], such a system consists of three distinct levels (Fig. 1). The controller is a discrete-state system, a sequential machine, seen as a Discrete Event System (DES). The controller receives, manipulates and outputs events represented by symbols. The plant is a continuous-state system typically modelled by differential equations; it is the system to be controlled by the discrete-state controller. The plant receives, manipulates and outputs signals represented by real variables that are typically (piecewise) continuous. The controller and the plant communicate via the interface that translates plant outputs into symbols for the controller to use, and controller output symbols into command signals for the plant input. The interface can be seen as consisting of two subsystems: the generator that senses the plant outputs and generates symbols representing plant events, and the actuator that translates the controller symbolic commands into piecewise constant plant input signals. Hybrid systems are conventionally modelled by switching patterns using the whole system instead of atomic resource. Therefore, the reconfiguration process is complex because it must take into account the system as a whole. Hence, there is need to find new architectures for these hybrid systems in order to improve their flexibility and reconfigurability.

**Fig. 1** Hybrid systems architecture

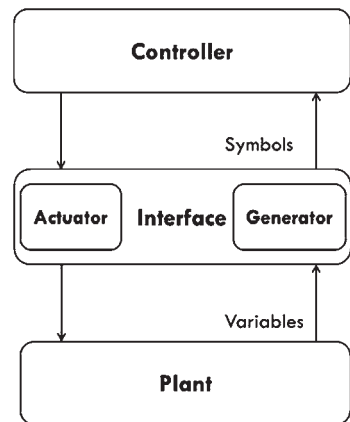

It is well known that holonic architectures [2–4] are flexible architectures which allow online reconfiguration of processes. A holonic manufacturing architecture shall enable easy (self-) configuration, easy extension and modification of the system, and allow more flexibility and a larger decision space for higher control levels. The structure of the PROSA reference architecture is built around three types of basic holons: order holons, product holons, and resource holons. Each of them is responsible for one aspect of manufacturing control, be it logistics, technological planning, or resource capabilities respectively. Although there are other holonic architectures, PROSA presents the advantage of being more conceptual, and therefore less application dependent than the others, specifically made for discrete-event manufacturing systems. Even if holonic architectures were designed for discrete manufacturing systems, some authors have proposed the use of holonic models for continuous systems [5–7]. However, all these works develop specific architectures, and do not consider the implementation of conventional holonic systems like PROSA on hybrid systems. The objective of this paper is to demonstrate the possibility of using PROSA to model a hybrid system. The paper is based on modelling a case study of hybrid systems, namely “water treatment process”, initially proposed by Villa et al. [8].

In chapter Optimizing Power Consumption in Robotized Job-Shop Manufacturing the state of the art of holonic modeling of hybrid systems is provided. Then an explanation of the case study is carried out in chapter Coupling Predictive Scheduling and Reactive Control in Manufacturing: State of the Art and Future Challenges, and this chapter develops the holonic modeling of the water factory.

## 2 State of the Art

The application of holonic systems on continuous systems has been studied by several authors. An implementation of holonic production system on a continuous system is proposed by McFarlane [5]. The framework showed in Fig. 2 internally converts goals or requirements into an allowable set of parameters or trajectories of behaviour via some form of decision function, D. The actual control action is then carried out in process P. The terminology in Fig. 2 is as follows:

Fig. 2 Control framework for HMS

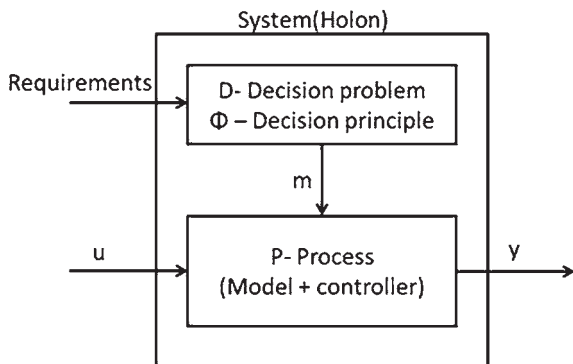

- P: process (model + controller);
- D: decision problem;
- $\Phi$ : decision principle;
- m: set of alternate decisions;
- u: set of alternate events;
- y: set of possible outcomes;

where  $m \in M, u \in U, y \in Y, P : M \times U \rightarrow Y$ .

The development of appropriate (and flexible) decision problems is the key to embedding control activity within holonic systems whose goals may differ depending on the environment that they operate in. It is clear from the test cases that a distributed optimization based decision principle is well suited to holonic systems, and the goal-seeking methods could help with the integration of complex optimization based control algorithms into manufacturing operations—a relatively uncommon event at present. Another holonic architecture developed for continuous systems is that proposed by Chacón et al. [6]. It proposes a holonic structure based on a decision making system called production unit (Fig. 3). This unit is the foundation for exploiting the fractal structure characteristic of holonic systems. The aggregation of production units is then called complex production system.

The production unit has physical (raw materials, finished goods, services) and logical (goals, state information) inputs and outputs. In addition, this production unit follows a holonic structure composed of three bases holon called resource holon, mission-product holon and engineering holon. Finally, the work developed by Chokshi and McFarlane [7] shows an approach to distributed coordination process for reconfigurable control. In this work, a control architecture is developed using four basic elements such as the *product element*, the *unit element*, the *header* and the *service element*. Although it does not explicitly address the holonic paradigm, the goal of this architecture is to have a control system based on reconfigurable and flexible interaction models, similar to holonic systems and it can be implemented in continuous and semi-continuous processes.

Fig. 3 Production unit

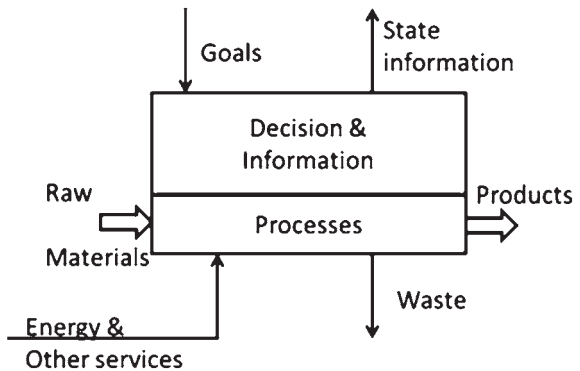

### 3 Case Study

The studied process is the drinking water treatment plant of Bogota (Colombia), at an altitude of 2,800 m. The plant uses 16 filters in a parallel configuration treating on average a flow rate of 12 m<sup>3</sup>/s. The volume of water produced by this plant covers up to 60 % of consumption of Bogota city. This plant has two water sources, Chingaza and San Rafael which can provide a flow rate of 22 m<sup>3</sup>/s.

Production of drinking water is achieved through physical, chemical, and biological processes that transform inlet source water to drinking water. However, inlet water quality is highly variable by natural perturbations and/or occasional pollution. A simplified diagram of water treatment plant is presented in Fig. 4. Input variables are pH, turbidity, alkalinity, colour and volume of inlet water. Key steps in treatment process are coagulation, flocculation, filtration, pH correction and bacterial correction.

This water treatment plant is classified into direct in-line filtration because the flocculation occurs in the filter itself. The operation of direct filtration is of lower time with respect to conventional treatment plants, and automatic tuning of the coagulant dosage is highly desirable. The case study is focused on the removing-turbidity sub-process. The inlet water is mixed with chemical coagulant additive used for accelerating the aggregation of particles, the aggregated particles of appropriated size stay seized in the filters. Interaction between chemical coagulant and suspension particles in water can be measured by ionic potential caused by charged particles motion, because it is a measure of charged particles neutralization. This potential is named Z potential. The on-line measurement of Z potential is difficult; however it is possible to measure a related variable named Streaming Current (SC), that is the current caused by superficial ions of suspension particles

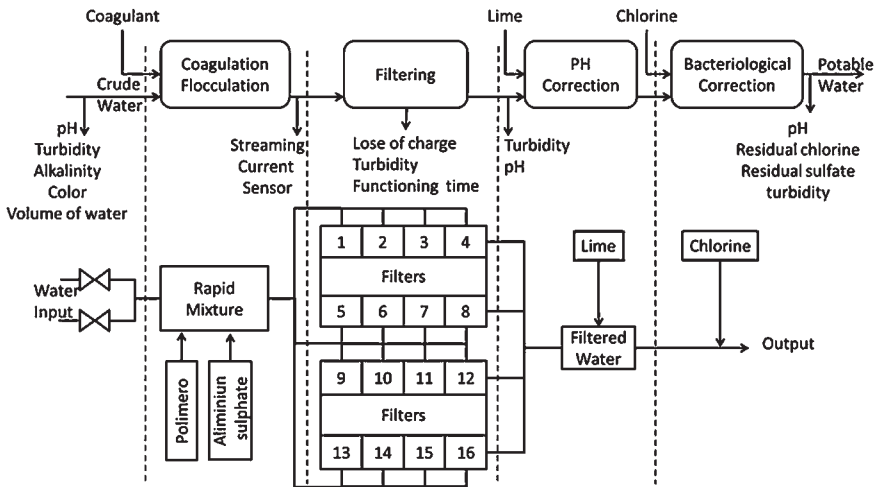

Fig. 4 Simplified diagram of the water treatment process

and there exists a direct relationship between SC and Z potential. The filtration mechanism is composed of several and complex physical phenomena and a universally accepted model is not available. Each filter has two measured variables: head loss (HL) and outlet water turbidity ( $T_{-}$ ). Head loss represents the difference of the pressure between surface of highest bed and lower surface of lowest bed of the filter. The head loss occurs when water flows pass through a bed of filter and the particles with a given size stay in the interstitial spaces of the bed. The volume of water capacity of filters becomes lower, as normally the filters are operated at a constant rate. Thus, the pressure of inlet water has to be increased. Head loss increases with the operation time, and volume of water treated.

Outlet water turbidity of each filter is a measure of filter efficiency and a function of head loss and size of suspension particles. If the size of suspension particles is big enough, they stay in the filter; otherwise, the particles with small size will pass the filter with the outlet water. Therefore, if the head loss increases, the interaction forces between filter material and retained particles are broken and turbidity increases too. When the head loss or turbidity reaches a predetermined threshold or when the maximal operation time is reached, the filter has to go into a backwashing process. Using this general description of the process the following components can be extracted:

- *Continuous variables*: influent turbidity, pH, streaming current, volume of water, loss of charge (LC) and effluent turbidity (TF).
- *Discrete Variables*: water source (op), backwashing (BW) operation, operation time. A state transition diagram of water treatment plant operation is shown in Fig. 5, extracted from the modelling of the system presented in [8].

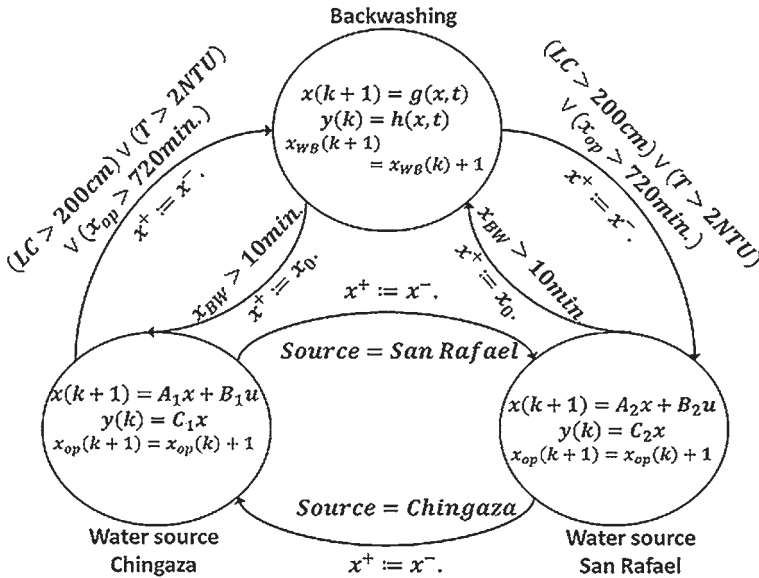

Fig. 5 State transition diagram of water treatment plant operation

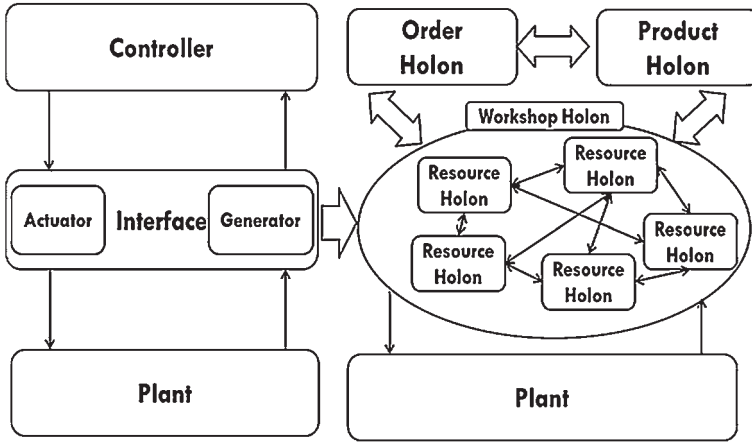

Fig. 6 Holonic architecture of a hybrid system

- *Controlled switching*: each water source represents a different behaviour of the continuous variables: streaming current, effluent turbidity and head loss.
- *Autonomous Jumps*: each backwashing operation re-initializes the continuous variables associated to the filter: effluent turbidity, head loss and operation time.

## 4 Holonic Modelling

Figure 6 illustrates the transition of conventional hybrid systems into the holonic paradigm of model system. Hybrid control architectures are composed of three parts: controller, interface and plant. In this holonic hybrid system model, the controller is represented by product and order holons, the interface is by the logical part of the resource holons and the production system by the physical part of the resource holons.

### 4.1 Product Holon

According to PROSA [2], in discrete event systems the product holon contains knowledge of the process and product to ensure the correct performance of the product with sufficient quality.

In hybrid context, a service-oriented specification as proposed in [9] is well suited for the product specification. The distinction made in this article with respect to the definition used in [9] is that the parameters and variables of the service can be continuous or discrete. In our case study, the product holon is related to the drinking water, characterized by quality requirements. The quality levels are measured on the



system using pH, residual chlorine, residual sulfate and turbidity sensors. Using the definition of parameterizable services, general product recipes can be created. Two cases may appear: on cases like the one presented here, a single general recipes is defined, with flexibility granted on parameters definition in order to cope with the water quality evolution along time. The parameters that parameterize services here are: aluminium sulfate amount, chlorine amount and lime amount. On other cases, several general recipes may be defined, in order to illustrate the possibility to modify the order of the services application to the product. In this configuration, the product holon is in charge of the instantiation of the general recipe using the available resources in order to cope with the quality requirements.

### 4.2 Resource Holon

The resource holon is composed by a physical part and a logical part. The physical part is represented by the plant, and in our case study is divided into five holons (Fig. 7): the input switching system (2 valves), the Aluminium sulfate injection system (11 tanks and 10 pumps) the filtering and backwashing system (16 filters, 2 tanks and 5 bombs), the lime injection system (1 silo, 2 heaters, 2 outrigger and 3 pumps) and the chlorine injection system (10 scales, 4 evaporators, 5 chlorinators and 18 valves). Each system contains enough elements for establishing switching control policy, so that each system has hybrid behaviour. The logical part of the resource holon is an abstraction of the physical part and contains the conversion models from continuous states to discrete states and vice versa. The models used are hybrid Petri nets that change their state using threshold levels of continuous

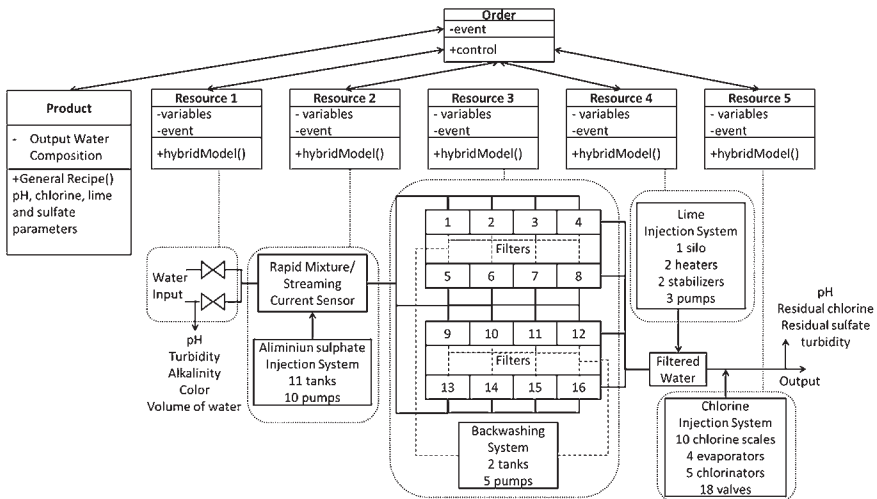

Fig. 7 Simplified diagram of the water treatment process

variables (pH, SC, turbidity). Several models can coexist in the resource holon and represent features such as fault detection model, the desired behaviour model and models that are inherent in holonic paradigm as a negotiation model for example.

One of the main features of the resources is to be able to compute the optimal parameters set in order to fit the requirements of the holarchy. Therefore, the resources are fractally decomposed into sub resources, able to negotiate with one another, until reaching the lowest level of resources, where it is possible to define the optimal set of parameters using differential equation solving.

### ***4.3 Order Holon***

The function and structure of order holons remain the same as in PROSA. Indeed, the architecture proposed in this paper guarantees that all information and models to be manipulated by the order holon are discrete or discretized. The discretization process of control variables is conventionally used in the control of hybrid systems; the difference with our proposition is that the behaviour model of each holon is simpler than the overall behaviour model of the hybrid system, and therefore easier to discretize. In our case study, the order holon has the responsibility for controlling the amount of water to be treated and the resource coordination to ensure the product quality establishing the goals to achieve for each resource holon. When a new order is placed, the associated product holon computes the best recipe and the best set of parameters to be used in order to optimize the production. This evaluation might be repeated when a severe disruption occurs and modifies the expected performance of the system. Sub-order holons are also created to assign production goals to resources, goals that they shall propagate to sub resources with the creation of new sub-order holons.

## **5 Conclusion**

The work proposed in this paper concerns the implementation of a holonic architecture for hybrid systems. The model presented tends to confirm the good fit of the classical reference architecture PROSA to this class of systems. The holonic architecture also provides its intrinsic simplicity, simplest management models behaviour and flexibility, with the possibility to reconfigure resources online.

Therefore, further work will cover aspects of resource planning and fault tolerance models and propose new adaptation of other holonic reference architectures such as ADACOR or HCBA.

**Acknowledgments** This work was partly funded by the ECOS-Nord n° V11M01 Program (Ministry of Foreign Affairs of France and FONACIT Ministry of Science and Technology of Venezuela).

## References

1. Koutsoukos, X.D., Antsaklis, P.J., Stiver, J.A., Lemmon, M.D.: Supervisory control of hybrid systems. *Proc. IEEE* **88**(7), 1026–1049 (2000)
2. Van Brussel, H., Wyns, J., Valckenaers, P., Bongaerts, L., Peeters, P.: Reference architecture for holonic manufacturing systems: PROSA. *Comput. Ind.* **37**(3), 255–274 (1998)
3. Leitão, P., Restivo, F.: ADACOR: a holonic architecture for agile and adaptive manufacturing control. *Comput. Ind.* **57**(2), 121–130 (2006)
4. Chirn, J.-L., McFarlane, D.C.: A holonic component-based approach to reconfigurable manufacturing control architecture. In: *Proceedings of 11th International Workshop on Database and Expert Systems Applications 2000*, pp. 219–223 (2000)
5. McFarlane, D.C.: Holonic manufacturing systems in continuous processing: concepts and control requirements. In: *Proceedings of ASI*, vol. 95, pp. 273–282 (1995)
6. Chacón, E., Besembel, I., Narciso, F., Montilva, J., Colina, E.: An integration architecture for the automation of a continuous production complex. *ISA Trans.* **41**(1), 95–113 (2002)
7. Chokshi, N., McFarlane, D.: A distributed architecture for reconfigurable control of continuous process operations. *J. Intell. Manuf.* **19**(2), 215–232 (2008)
8. Villa, J.L., Duque, M., Gauthier, A., Rakoto-Ravalontsalama, N.: Modeling and control of a water treatment plant. In: *IEEE international conference on systems, man and cybernetics*, vol. 1, pp. 171–176 (2003)
9. Gamboa Quintanilla, F., Cardin, O., Castagna, P.: Product specification for flexible workflow orchestrations in service oriented holonic manufacturing systems. In: Borangiu, T., Trentesaux, D., Thomas, A. (eds.) *Service Orientation in Holonic and Multi-Agent Manufacturing and Robotics*, pp. 177–193. Springer, Berlin (2014)